

MOS Field Effect Transistor

KPA1716

■ Features

- Low on-state resistance
 $R_{DS(on)1} = 12.5 \text{ m}\Omega$ TYP. ($V_{GS} = -10 \text{ V}$, $I_D = -4 \text{ A}$)
 $R_{DS(on)2} = 17 \text{ m}\Omega$ TYP. ($V_{GS} = -4.5 \text{ V}$, $I_D = -4 \text{ A}$)
 $R_{DS(on)3} = 19 \text{ m}\Omega$ TYP. ($V_{GS} = -4.01 \text{ V}$, $I_D = -4 \text{ A}$)
- Low C_{iss} : $C_{iss} = 2100 \text{ pF}$ TYP.
- Built-in G-S protection diode
- Small and surface mount package

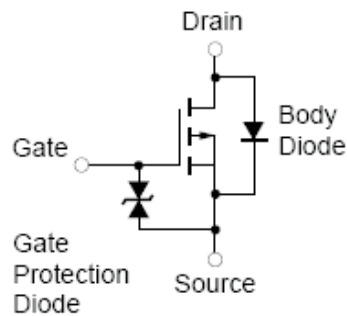
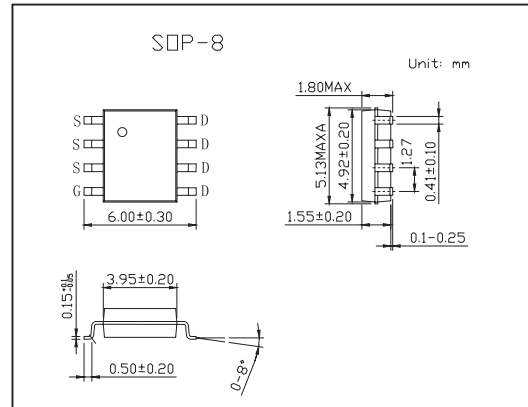

■ Absolute Maximum Ratings $T_a = 25^\circ\text{C}$

Parameter	Symbol	Rating	Unit
Drain to Source Voltage ($V_{GS} = 0$)	V_{DSS}	-30	V
Gate to Source Voltage ($V_{DS} = 0$)	V_{GSS}	± 20	V
Drain Current (DC) $T_a = 25^\circ\text{C}$	$I_D(\text{DC})$	± 8	A
Drain Current (Pulse) *1	$I_D(\text{pulse})$	± 32	A
Total Power Dissipation $T_a = 25^\circ\text{C}$ *2	P_T	2.0	W
Channel Temperature	T_{ch}	150	$^\circ\text{C}$
Storage Temperature	T_{stg}	-55 to + 150	$^\circ\text{C}$

*1 $PW \leq 10 \mu\text{s}$, Duty cycle $\leq 1\%$

*2 Mounted on ceramic substrate of $1200\text{mm}^2 \times 1.0 \text{ mm}$

KPA1716

■ Electrical Characteristics Ta = 25°C

Parameter	Symbol	Testconditons	Min	Typ	Max	Unit
Drain to Source On-state Resistance	R _{DS(on)1}	V _{DS} = -10V, I _D = -4.0 A		12.5	16	mΩ
	R _{DS(on)2}	V _{GS} = -4.5V, I _D = -4.0 A		17	23	mΩ
	R _{DS(on)3}	V _{GS} = -4.0V, I _D = -4.0 A		19	26	mΩ
Gate Cut-off Voltage	V _{GS(off)}	V _{DS} = -10 V, I _D = 1 mA	-1.0	-1.6	-2.5	V
Forward Transfer Admittance	y _{fs}	V _{DS} = 10 V, I _D = -4.0A	7	14		S
Zero Gate Voltage Drain Current	I _{DSS}	V _{DS} = -30 V, V _{GS} = 0			-1	μA
Gate Leakage Current	I _{GSS}	V _{GS} = ±20V, V _{DS} = 0			±10	μA
Input Capacitance	C _{iss}	V _{DS} = -10 V, V _{GS} = 0, f = 1 MHz		2100		pF
Output Capacitance	C _{oss}			700		pF
Reverse Transfer Capacitance	C _{rss}			300		pF
Turn-on Delay Time	t _{d(on)}	I _D = -4.0 A, V _{GS(on)} = -10 V, V _{DD} = -15 V, R _G = 10 Ω		30		ns
Rise Time	t _r			150		ns
Turn-off Delay Time	t _{d(off)}			120		ns
Fall Time	t _f			76		ns
Total Gate Charge	Q _G	I _D = -8.0A, V _{DD} = -24V, V _{GS} = -10 V		40		nC
Gate to Source Charge	Q _{GS}			6		nC
Gate to Drain Charge	Q _{GD}			10		nC
Body Diode forward Voltage	V _{F(S-D)}	I _F = 8.0 A, V _{GS} = 0		0.8		V
Reverse Recovery Time	t _{rr}	I _F = 8.0 A, V _{GS} = 0 V		45		ns
Reverse Recovery Charge	Q _{rr}	di/dt = 100 A/μs		33		nC